



Short communication

A technique for conditioning and calibrating force-sensing resistors for repeatable and reliable measurement of compressive force

Rick S. Hall^{b,d}, Geoffrey T. Desmoulin^{c,d,1}, Theodore E. Milner^{a,d,*}^a Department of Kinesiology and Physical Education, McGill University, Montreal, QC, Canada H2W 1S4^b Children's & Women's Health Centre of B.C., Rm. A305 Shaughnessy Building, Injury Prevention, Employee Wellness & Safety, Provincial Health Services Authority, 4500 Oak Street, Vancouver, Canada V6H 3N1^c Department of Biomedical Engineering, Wayne State University, Detroit, MI 48201, USA^d School of Kinesiology, Simon Fraser University, Burnaby, Canada V5A 1S6

ARTICLE INFO

Article history:

Accepted 23 September 2008

Keywords:

Force-sensing resistors

Compression

Hysteresis

Shear sensitivity

ABSTRACT

Miniature sensors that could measure forces applied by the fingers and hand without interfering with manual dexterity or range of motion would have considerable practical value in ergonomics and rehabilitation. In this study, techniques have been developed to use inexpensive pressure-sensing resistors (FSRs) to accurately measure compression force. The FSRs are converted from pressure-sensing to force-sensing devices. The effects of nonlinear response properties and dependence on loading history are compensated by signal conditioning and calibration. A fourth-order polynomial relating the applied force to the current voltage output and a linearly weighted sum of prior outputs corrects for sensor hysteresis and drift. It was found that prolonged (>20 h) shear force loading caused sensor gain to change by approximately 100%. Shear loading also had the effect of eliminating shear force effects on sensor output, albeit only in the direction of shear loading. By applying prolonged shear loading in two orthogonal directions, the sensors were converted into pure compression sensors. Such preloading of the sensor is, therefore, required prior to calibration. The error in compression force after prolonged shear loading and calibration was consistently <5% from 0 to 30 N and <10% from 30 to 40 N. This novel method of calibrating FSRs for measuring compression force provides an inexpensive tool for biomedical and industrial design applications where measurements of finger and hand force are needed.

© 2008 Elsevier Ltd. All rights reserved.

1. Introduction

Conductive polymer pressure sensors known as force-sensing resistors (FSRs) respond to forces from 0.3 to 100 N, which corresponds approximately to the range recommended by Crago et al. (1986) for evaluation of hand function. It would seem feasible to use FSRs for general-purpose applications in recording hand and finger force during grasping and manipulation of arbitrary objects (Jensen et al., 1991; Radwin and Oh, 1992; Castro and Cliquet, 1997). However, FSRs exhibit considerable hysteresis, sensitivity to shear force and alterations in response properties with prolonged use. We have developed effective techniques that dramatically improve both the reliability and accuracy of measuring compression force with FSRs.

2. Methods

FSRs (Interlink Electronics) with an active area of 5 mm diameter were used in this study. To convert the sensor from a pressure- to a force-sensing device, we used a method devised by Jensen et al. (1991) in which a thin layer of epoxy, in the shape of a dome, is glued to the active sensing area. Domes (5 mm diameter flat section × 3 mm high) were made from fiberglass resin using a Teflon mold. The resin increased the rigidity of the sensor, thereby eliminating bending when the sensor was in contact with curved surfaces. Because the dome was very rigid it did not interfere with the sensitivity or dynamic response of the sensor to compressive force.

Since the resistance of the conductive polymer sensor drops in an exponential fashion as the applied force is increased the output voltage will be a nonlinear function of the applied force. However, using an operational amplifier circuit the output can be made more linear over a desired range by adding a compensating resistor as shown in Fig. 1A. The output voltage, V_o , of this circuit is given by

$$V_o = V_i \frac{R_d(R_a + R_b)}{R_a(R_c + R_d)} \quad (1)$$

The value of R_d should be equal to half the sensor resistance when no force is applied ($0.5R_c$ when $F = 0$).

We found that the sensors changed their resistance with repeated use. To eliminate this problem the sensors were preloaded on a 45° angled platform to apply both compressive and shear loads. A torque motor (PMI Motion Technologies) was used to dynamically vary the forces applied to a sensor under computer control (Fig. 1B). Torque and sensor output voltage were sampled at

* Corresponding author at: Department of Kinesiology and Physical Education, McGill University, Montreal, QC, Canada H2W 1S4. Tel.: +1 514 398 4184x0477; fax: +1 514 398 4186.

E-mail addresses: richhall@telus.net (R.S. Hall), geoffd@wayne.edu (G.T. Desmoulin), theodore.milner@mcgill.ca (T.E. Milner).

¹ Tel.: +1 313 833 4331.

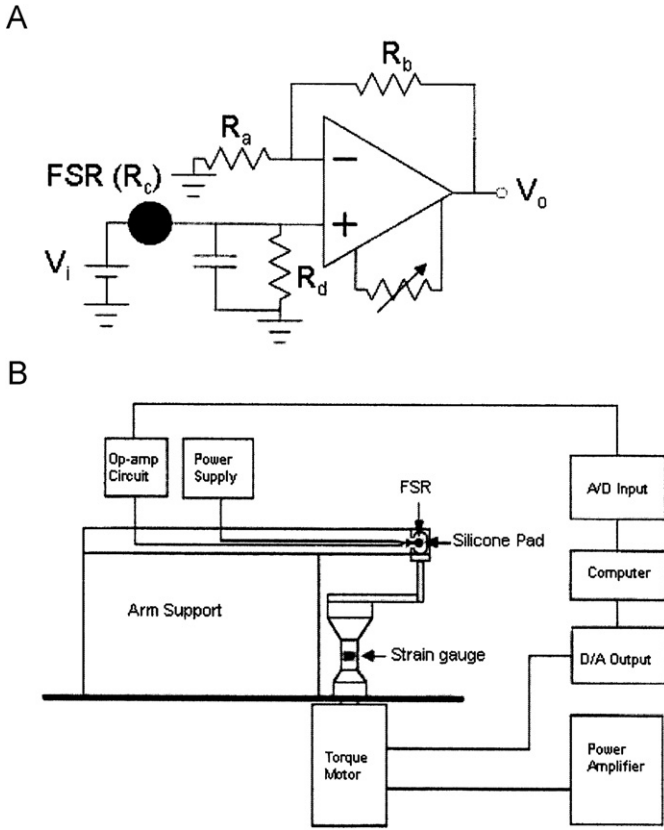

Fig. 1. (A) Signal conditioning circuit. (B) Torque motor, signal conditioning and data acquisition system used for calibration of force sensing resistors (FSRs).

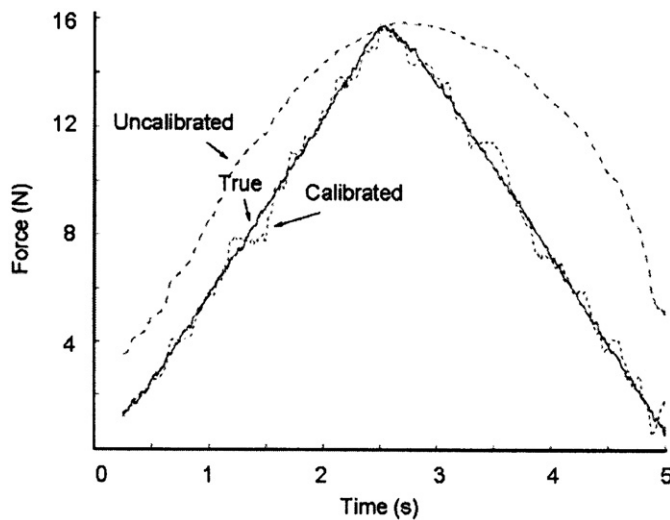

Fig. 2. Response of FSR (dashed line) to increase and decrease ramp compressive force (solid line) of 16 N. Uncalibrated output represents linear scaling of output voltage to match peak ramp force. Calibrated output (dotted line) represents output voltage transformed by Eq. (2). Note that the calibration compensates for the hysteresis, evident as higher output voltage in the uncalibrated output during the decreasing ramp.

100 Hz. Calibration with static loads is inadequate as the FSRs exhibit hysteresis (Fig. 2). To compensate for hysteresis, we assumed that the output voltage depended on the loading history represented as a moving integral. Specifically, the output voltage more than 0.5 s in the past was multiplied by 0 whereas the sampled output voltages from the past 0.5 s to the current time were multiplied by linearly increasing weights and then summed. A polynomial regression equation was used to predict compression force with terms that depended on both the current output voltage (V) and the moving integral (I). The results of stepwise

regression indicated that there were significant improvements in fitting the data as the order of the polynomial was increased from first to fourth order. Consequently, the following fourth-order polynomial equation was used in calibrating the FSRs:

$$F = a_0 + a_1V + a_2V^2 + a_3V^3 + a_4V^4 + b_1I + b_2I^2 + b_3I^3 + b_4I^4 \quad (2)$$

where F is the predicted applied force. Because the properties of each FSR are slightly different it must be separately calibrated and assigned a unique set of coefficients. Approximately 50 FSRs were calibrated and used in the various tests described in the Results. Statistical analysis of force errors under different conditions involved comparison of the mean of these single measurements made with multiple force sensors (the number of sensors is indicated by the value of n) using a t -test with $\alpha = 0.05$.

3. Results

After applying Eq. (2) the predicted compression force (calibrated) much more closely matched the applied force (Fig. 2). Thereafter, arbitrary compression force profiles could be applied to the sensor with relatively little force error (Fig. 3). The mean force prediction error during 5-s tests, in which force was arbitrarily varied was 3.2% (s.d. 1.3%, $n = 11$). Application of shear force in combination with compression force resulted in a relatively large prediction error in the compression force since sensor output voltage increased (Fig. 4A). The mean prediction error was 32% (s.d. 5.6%, $n = 5$) at 10 N of shear force with an average compression force of 9.6 N and 57% (s.d. 9.2%, $n = 5$) at 20 N of shear force with an average compression force of 10.7 N.

Prolonged loading with combined shear and compression forces resulted in an increase in sensor gain (Fig. 4B) such that the prediction error for pure compression forces increased ($p < 0.0001$) when the calibration coefficients determined prior to prolonged loading were used. The prediction error increased from 5.1% (s.d. 1.3%, $n = 4$) to 92% (s.d. 9.8%, $n = 4$) for 20 h of loading at 20 N. Similar results were obtained with 40 N loading.

Prolonged shear loading decreased the sensitivity to shear force (Fig. 4C). Four sensors were calibrated with pure compression forces and tested for sensitivity to shear loading by adding a 10 N shear load during measurement of compression force. The mean prediction error for compression force was 36% (s.d. 8.4%, $n = 4$). After compression and shear loading for 20 h the sensors were recalibrated with pure compression forces and again tested for shear sensitivity. The mean prediction error for compression force was reduced significantly ($p = 0.0001$) to 2.8% (s.d. 2.2%, $n = 4$). Additional loading for 10 h did not further reduce the error. However, the loss in shear sensitivity occurred only in the

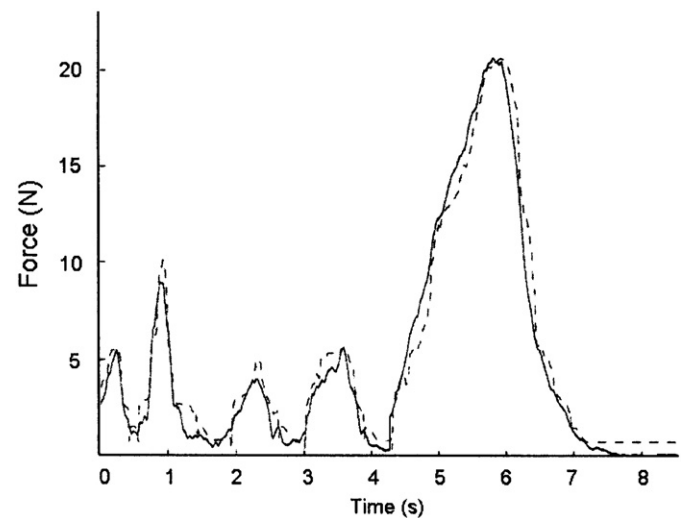

Fig. 3. Calibrated FSR output (dashed line) in response to arbitrary modulation of applied compressive force (solid line) over a 20 N range.

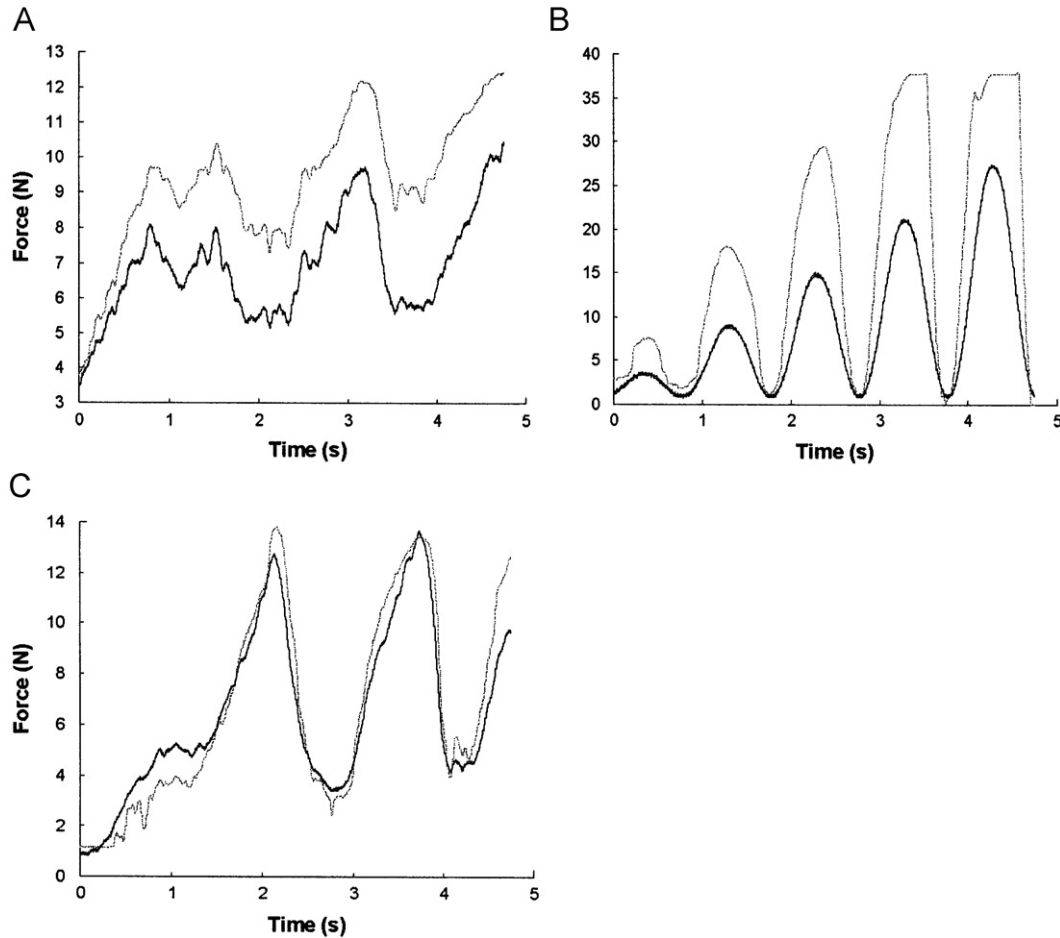

Fig. 4. (A) Comparison between the applied compressive force (black line) with a constant shear force of 10 N and the predicted compressive force (grey line), using coefficients obtained during calibration with pure compressive forces. (B) Comparison between the applied compressive force (black line) without shear loading and the predicted compressive force (grey line), using coefficients obtained prior to prolonged shear loading. (C) Comparison between the applied compressive force (black line) with a constant shear force of 10 N and the predicted compressive force (grey line), using calibration coefficients obtained after prolonged shear loading.

direction of shear loading. Sensors still displayed shear sensitivity in directions 90° and 270° to the loading direction. The mean prediction error in compression force when shear force was applied at 90° and 270° to the loading direction was 19% (s.d. 0.92%, $n = 2$), which was significantly higher than in the loading direction ($p = 0.0006$). Sensors loaded statically in two shear directions that were 90° apart displayed a loss of shear sensitivity in all four directions. In this case, the mean prediction error when shear force was applied in the first direction of loading and 180° to that direction was 2.8% (s.d. 1.8%, $n = 2$) and 3.5% (s.d. 1.9%, $n = 2$) when shear force was applied at 90° and 270° to the first loading direction.

4. Discussion

Two of the major limitations of using FSRs for measuring compression force in biomechanics applications have been addressed with the techniques described above. Compensation for hysteresis was achieved by incorporating terms dependent on past loading history in the calibration equation. Sensitivity to shear loading was eliminated by prolonged preloading of the sensors in compression and shear.

The elimination of shear sensitivity is likely due to permanent deformation of the polymer during prolonged shear loading similar to that experienced by rubber that has been subjected to

elongation in a tensile test (Hoffmann, 1980). The loss in shear sensitivity was found to be sensitive to the direction of shear loading. Shear loading in one direction may tend to stretch out the material matrix of the polymer in that direction only. In directions orthogonal to the loading direction, the material matrix may not have undergone plastic deformation. Shear loading in a given direction also reduced shear sensitivity in directions that were 180° to that direction, as would be expected if the limits of plastic deformation had been achieved.

By attaching FSRs to a pinch grip dynamometer we confirmed that calibrated FSRs could measure compression force exerted by the fingers as accurately as compression force exerted by the torque motor (Hall, 2000). The error between the finger force measured by the dynamometer and the calibrated FSR force was similar to that shown in Fig. 3. Multiple FSRs can be incorporated into gloves made of thin material such as Lycra (Castro and Cliquet, 1997; Hall, 2000). Such material does not limit range of motion in any noticeable way. Although it does reduce manual dexterity by interposing a thin layer between the skin and a manipulated object, it adds little additional impediment to that already created by the sensor. We have tested prolonged use of such a glove incorporating 11 FSRs located on the fingertips and palm, worn during performance of ultrasound scans lasting up to 30 min in duration (Hall, 2000). Sonographers performed a variety of standard diagnostic procedures, including abdominal scans, vascular scans and cardiac scans while wearing the glove without

impediments to their manual dexterity. No adverse effects on performance or comfort were reported. Consequently, there is considerable potential for FSRs to be used in applications such as the design of hand held instruments and tools where the ability to accurately measure contact forces has implications for quantifying important ergonomic factors such as comfort and fatigue. Similarly, forces applied by the fingers and hand could be measured on the job to assess risk of repetitive strain injury. Finger force measurements could also serve a diagnostic function in clinical assessment of impaired function. Forces applied by the fingers and hand could be used as biofeedback for rehabilitation after injury or to facilitate recovery of motor function in disorders of neural control such as stroke.

Conflict of interest statement

None of the authors (Rick Hall, Theodore Milner, Geoffery Desmoulin) has any conflict of interest relating to the manuscript entitled, "A procedure for conditioning and calibrating force-sensing resistors for repeatable and reliable measurement of compressive force" being submitted for publication in the Journal of Biomechanics.

Acknowledgement

This work was supported by grants from the Vancouver Foundation and Healthcare Benefit Trust.

References

- Castro, M.C.F., Cliquet, J.A., 1997. A low-cost instrumented glove for monitoring forces during object manipulation. *IEEE Transactions on Rehabilitation Engineering* 5, 140–147.
- Crago, P.E., Chizeck, H.J., Neuman, M.R., Hambrecht, F.T., 1986. Sensors for use with functional neuromuscular stimulation. *IEEE Transactions on Biomedical Engineering* 33, 256–268.
- Hall, R.S., 2000. Design of a Force Sensing Glove for Ergonomic Evaluation. Simon Fraser University, Burnaby.
- Hoffmann, W., 1980. *Rubber Technology Handbook*. Oxford University Press, Oxford.
- Jensen, T.R., Radwin, R.G., Webster, J.G., 1991. A conductive polymer sensor for measuring external finger forces. *Journal of Biomechanics* 24, 851–858.
- Radwin, R.G., Oh, S., 1992. External finger forces in submaximal five-finger static pinch prehension. *Ergonomics* 35, 275–288.